

30000 SERIES

SR Range



Motor driven compact reel

Reelcare's 30000 Series reels with large storage capacity are designed for harsh, heavy duty applications* that require long lengths of hose. The 30000 Series come in manual and motor driven versions and have many configurations. 30000 Series reels are manufactured from high quality steel components which are individually powder coated to give added corrosion resistance. Each reel is supplied complete with a full flow swivel assembly to allow for maximum product delivery. Available to suit maximum lengths of the following hose sizes:

300m - 1/4", 210m - 3/8", 150m - 1/2", 84m - 3/4", 53m - 1"

Further models are available in addition to the table below, consult Reelcare for more information.



ELECTRIC	HYDRAULIC	AIR	I.D.		O.D.		LENGTH	PRESSURE		CON. inlet	WGT Kg	DIMENSIONS				
			mm	inch	mm	m		ft	Bar			PSI	W (EA)	W (HA)	W (AA)	L
All reels list are without hose, price available on application																
Low Pressure Air & Water																
EA37118 L12D118	HA37118 L118	AA37118 L6A118	25	1	35	30	100	35	500	1	25	752	735	785	451	514
EA37122 L12D118	HA37122 L118	AA37122 L6A118	25	1	35	45	150	35	500	1	27	866	836	886	451	514
EA37128 L12D118	HA37128 L118	AA37128 L6A118	25	1	35	54	175	35	500	1	30	1018	988	1038	451	514
*Medium Pressure Air, Water Oil & Fuel																
EA32106 M12D118	HA32106 M118	AA32106 M4A118	12	1/2	22	30	100	207	3000	1/2	18	460	430	440	451	514
EA32112 M12D118	HA32112 M118	AA32112 M4A118	12	1/2	22	60	200	207	3000	1/2	21	612	582	591	451	514
EA32118 M12D118	HA32118 M118	AA32118 M4A118	12	1/2	22	99	325	207	3000	1/2	25	765	735	744	451	514
EA32122 M12D118	HA32122 M118	AA33106 M4A118	12	1/2	22	120	400	207	3000	1/2	27	866	836	845	451	514
EA32128 M12D118	HA32128 M118	AA33112 M4A118	12	1/2	22	150	500	207	3000	1/2	30	1018	988	1038	451	514
EA33106 M12D118	HA33106 M118	AA32122 M6A118	19	3/4	31	15	50	207	3000	3/4	18	498	430	438	451	514
EA33112 M12D118	HA33112 M118	AA32128 M6A118	19	3/4	31	30	100	207	3000	3/4	21	602	582	591	451	514
EA33118 M12D118	HA33118 M118	AA33118 M6A118	19	3/4	31	54	175	207	3000	3/4	25	752	735	785	451	514
EA33122 M12D118	HA33122 M118	AA33122 M6A118	19	3/4	31	68	225	207	3000	3/4	27	866	836	886	451	514
EA33128 M12D118	HA33128 M118	AA33128 M6A118	19	3/4	31	84	275	207	3000	3/4	30	1018	988	1038	451	514

***Please note: The 30000 Series is not suitable for drain jetting applications**

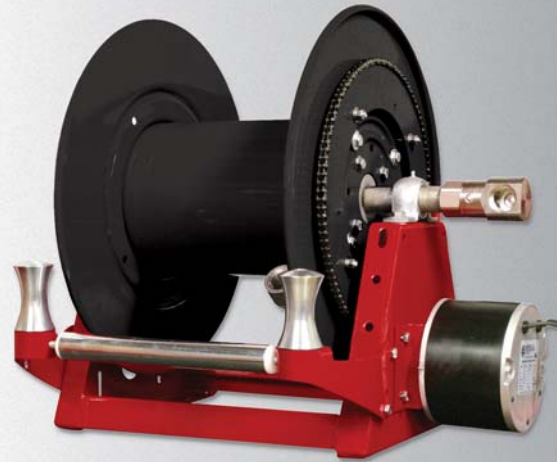

1200 SERIES

SR Range



Motor driven large frame reel

Heavy duty hose reel for use with hose sizes 1/2" to 1" I.D.

REWIND: Chain and sprocket drive powered by AC or DC electric motor, compressed air motor or hydraulic motor. Auxiliary hand crank is not supplied on power rewind models as standard, but is available on request.

INLET: 1/2" up to 1" female 90° swivel assembly as standard. Inline swivel assembly is available as an accessory.

GOOSENECK: 1/2", 3/4", 1" female. Other sizes or threads are available and can be supplied when specified.

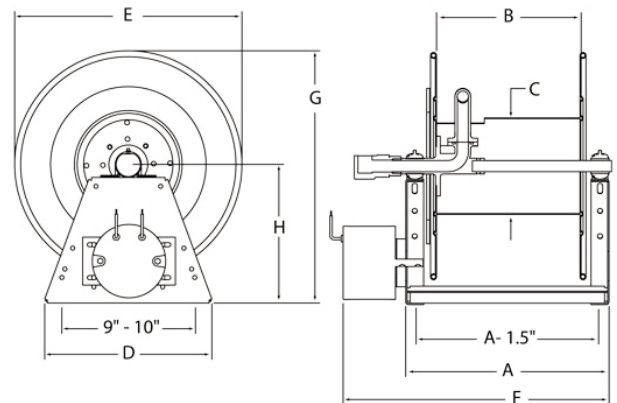

Models are listed without hose, hose available on request

MODEL	HOSE LENGTH																
		12mm 1/2"	19mm 3/4"	25mm 1"	WEIGHT		A	B	C	D	E	F "E"	F EP	F AIR	G	H	
1200-1910-6	ft	100	50	35	58	LB	in	11	6	8	14	19	16.5	18.5	16	21	11.6
	m	30	15	11	26	KG	mm	279	152	203	356	483	419	470	406	533	295
1200-19-12	ft	200	100	70	60	LB	in	17	12	8	14	19	22.5	24.5	22	21	11.6
	m	61	30	21	27	KG	mm	432	305	203	356	483	572	622	559	533	295
1200-19-18	ft	300	150	105	61	LB	in	23	18	8	14	19	28.5	30.5	28	21	11.6
	m	91	46	32	28	KG	mm	584	457	203	356	483	724	775	711	533	295
1200-19-22	ft	365	180	125	62	LB	in	27	22	8	14	19	32.5	34.5	32	21	11.6
	m	111	55	38	28	KG	mm	686	559	203	356	483	826	876	813	533	295
1200-19-28	ft	465	230	160	63	LB	in	33	28	8	14	19	38.5	40.5	38	21	11.6
	m	142	70	49	29	KG	mm	838	711	203	356	483	978	1029	965	533	295
1200-23-6	ft	150	75	50	66	LB	in	11	6	11.25	15.25	23	16.5	18.5	16	25.1	13.6
	m	46	23	15	30	KG	mm	279	152	286	387	584	419	470	406	638	345
1200-23-12	ft	300	150	100	68	LB	in	17	12	11.25	15.25	23	22.5	24.5	22	25.1	13.6
	m	91	46	30	31	KG	mm	432	305	286	387	584	572	622	559	638	345
1200-23-18	ft	450	225	150	69	LB	in	23	18	11.25	15.25	23	28.5	30.5	28	25.1	13.6
	m	137	69	46	31	KG	mm	584	457	286	387	584	724	775	711	638	345
1200-23-22	ft	550	275	180	70	LB	in	27	22	11.25	15.25	23	32.5	34.5	32	25.1	13.6
	m	168	84	55	32	KG	mm	686	559	286	387	584	826	876	813	638	345
1200-23-28	ft	700	350	230	71	LB	in	33	28	11.25	15.25	23	38.5	40.5	38	25.1	13.6
	m	213	107	70	32	KG	mm	838	711	286	387	584	978	1029	965	638	345

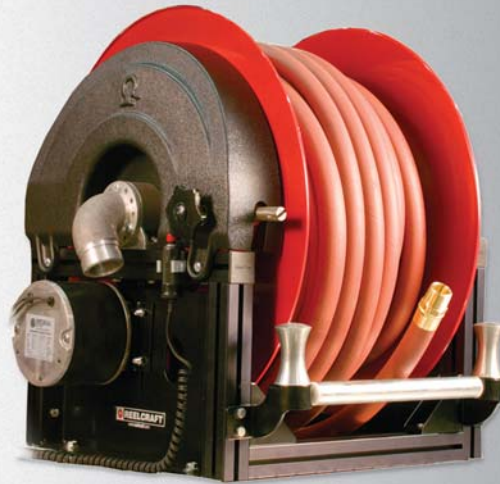

40 SERIES

SR Range



Large frame modular reels

The 40 Series revolutionary modular large frame design can be built to fit your space requirements. The 40 Series offers maximum strength yet is extremely lightweight, making it ideal for vehicle mounted applications. The anodised aluminium frame is combined with a stainless steel support shaft, stainless steel fasteners and powder coated flanges to offer the greatest amount of strength, corrosion resistance and durability.

The 40 Series, in addition to the standard items listed below can also offer dimensional flexibility. If you have height, width or depth restrictions, it may be possible to custom build a 40 Series to suit your envelope size, dependent on hose lengths and bore size.



Choose a motor type

- EH = Electric chain driven 12v
- EJ = Electric chain driven 24v
- XH = Electric chain driven 12v explosion proof
- XJ = Electric chain driven 24v explosion proof
- XA = Electric chain driven 115 explosion proof

- DH = Electric gear driven 12v
- DJ = Electric gear driven 24v
- MH = Electric gear driven 12v explosion proof
- MJ = Electric gear driven 24v explosion proof
- MA = Electric gear driven 115 explosion proof

- AC = Air chain driven 6am
- AG = Air gear driven 6am

- HC = Hydraulic chain driven
- HG = Hydraulic driven gear

Example part number: 412191DH1LC70
25mm I.D. x 60 meters with 12v direct gear drive

MODELS		PRESSURE	I.D.		LENGTH		DIMENSIONS			
Add ONE motor type		Bar	mm	in	m	ft	L	W	H	
412101	[?][?]	1LC70	41	25	1	30	100	635	552	660
412191	[?][?]	1LC70	41	25	1	60	200	635	781	660
413221	[?][?]	1LC70	41	25	1	100	325	737	857	737
422101	[?][?]	1LC70	41	32	1 1/4	25	80	635	552	660
422191	[?][?]	1LC70	41	32	1 1/4	45	140	635	781	660
423221	[?][?]	1LC70	41	32	1 1/4	75	250	737	857	737
432101	[?][?]	1LC70	41	38	1 1/2	15	50	635	552	660
432191	[?][?]	1LC70	41	38	1 1/2	30	100	635	781	660
433221	[?][?]	1LC70	41	38	1 1/2	60	200	737	857	737

DIMENSIONS are for EH only. Slight variations occur with air and hydraulic motors, please call for details