



## SRN Range

### Custom Reels

#### Reelcare's Custom Built Solutions

Reelcare offer custom built reels for applications that require strength and quality. Our large frame products suit hose sizes from 1" to 4" internal diameter hoses. Our heavy duty steel frames, engineered full flow swivel design and precise construction make Reelcare's large frame reels among the most reliable reels on the market. Reelcare are renowned for supplying quality hose reels to some of Europe's largest businesses. We have the resources to meet your specific hose reel requirements and go beyond our standard catalogue products.

An illustration of a typical custom built hose reel designed to your exact specification.

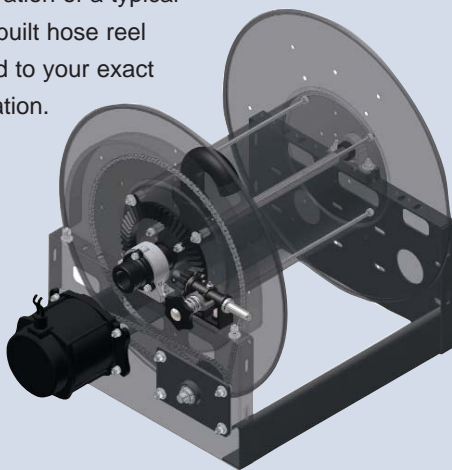

Due to the nature of specialist reel applications, each project will have different criteria. To outline our capabilities we have listed a few of the options available on our custom built reels. If required, we can arrange a visit to your site to discuss and advise how best to approach your application. Please feel free to contact Reelcare for more information.



Some available options are:

Corrosion resistance is a key part of any hose reel, so we offer reels in powder coated, galvanised and electropolished stainless steel options.

Goose necks are contoured to match the drum diameter, which allows smooth hose wrapping with minimal flow restriction.

All custom reels are manufactured with permanently lubricated roller bearings that ensure smooth drum rotation and extended service life.

A variety of drive options are available, including spring, manual, electric, air and hydraulic.

Reels can be built with working pressures up to 690bar

Multi port fluid paths are available to allow multiple hoses on one reel.

Many more choices are available.

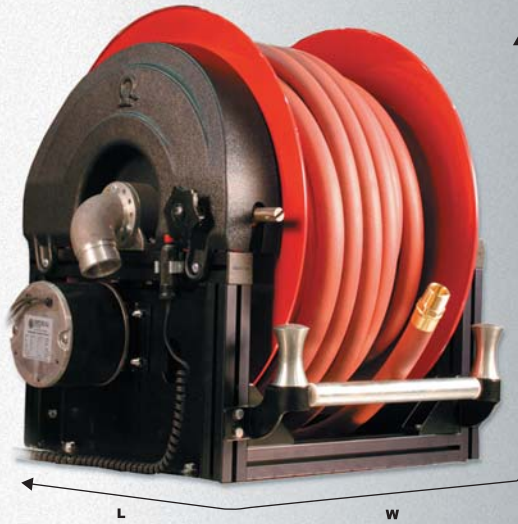

# 40 SERIES | SR Range

## Large Frame Modular Reels

The 40 Series revolutionary modular large frame design can be custom built to fit your space requirements. The 40 Series offers maximum strength yet is extremely lightweight, making it ideal for vehicle mounted applications. The anodised aluminium frame is combined with a stainless steel support shaft, stainless steel fasteners and powder coated flanges to offer the greatest amount of strength, corrosion resistance and durability.

The 40 Series, in addition to the standard items listed below can also offer dimensional flexibility. If you have height, width or depth restrictions, it may be possible to custom build a 40 Series to suit your envelope size dependent on hose lengths and bore size.



## Other Models Available

The table below shows standard manual and 12 volt motor driven versions. The 40 Series is also available with the drive options listed opposite. Contact Reelcare for details.

- 12V DC X-proof
- 24V DC
- 24V DC X-proof
- 110V AC X-proof
- Air Driven
- Hyd Driven

	MODELS				PRESSURE	I.D.	LENGTH		DIMENSIONS					
	Choose ONE drive type						Bar	mm	in	m	ft	L	W (BG)	W (EH/DH)
412101	CG	BG	EH	DH	1LC70	41	25	1	30	100	635	502	552	660
412191	CG	BG	EH	DH	1LC70	41	25	1	60	200	635	781	781	660
413221	CG	BG	EH	DH	1LC70	41	25	1	100	325	737	806	857	737
422101	CG	BG	EH	DH	1LC70	41	32	1 1/4	25	80	635	502	552	660
422191	CG	BG	EH	DH	1LC70	41	32	1 1/4	45	140	635	781	781	660
423221	CG	BG	EH	DH	1LC70	41	32	1 1/4	75	250	737	806	857	737
432101	CG	BG	EH	DH	1LC70	41	38	1 1/2	15	50	635	502	552	660
432191	CG	BG	EH	DH	1LC70	41	38	1 1/2	30	100	635	781	781	660
433221	CG	BG	EH	DH	1LC70	41	38	1 1/2	60	200	737	806	857	737

CG = Hand Crank    BG = Bevel Crank    EH = 12v DC Gear Drive    DH = 12v DC Chain Drive

Example part number: 412191CG1LC70 = 60m x 25mm Hand Crank